

Appearance

Sectional area	30X30mm
NO.of beams	4~32
Protection height	50~1240mm
Protection distance	0.3~3m
Beam pitch	10/14/20/25/30/40mm
Min. sized detectable objects	> ϕ 14/ ϕ 19/ ϕ 25/ ϕ 30/ ϕ 35/ ϕ 45mm, opaque
Supply voltage	24V DC \pm 10%
Current consumption	< 200mA
Power consumption	4~6W
Output type	NPN/PNP
Synchronization type	line synchronization
Response time	\leq 15ms
Light source	Infrared LED (Modulated)
Protective circuit	Reverse polarity, over-load, output short circuit protection
Ambient temperature	-10~+55°C (No condensation, no freezing)
Ambient humidity	35~85% RH
Anti-interference ability	10000Lux
Insulation resistance	Above 50M Ω (DC 500V megger)
Shock resistance	10~150Hz, double amplitude; 1.5mm, in each of x, y and z direction for 2 hours
Vibration resistance	Acceleration: 500m/s ² (Approx:50G); x, y and z direction (3 times each)
Degree of protection	IP65
Material	Housing: Aluminum alloy; Transmissive cover: Polyester; End cover: Reinforced nylon
Connection	M12 connector
Accessories	Cable length 3m, female (Customization available)

Area

Light curtains

Standard type

Top-emitting type

Side-emitting type

Waterproof type

Measuring type

Economical type

Safety Light Curtain

Beam pitch 10mm

Beam pitch 20mm

Beam pitch 30mm

Beam pitch 40mm

LIDAR scanner

TOF LIDAR scanner

MINI LIDAR scanner

Navigation LIDAR

BML10

Beam pitch	10mm							
Min. sized detectable objects	> ϕ 14mm, opaque							
Protection distance	0.3~3m							
NO.of beams	6	8	10	12	14	32	
Protection height	50mm	70mm	90mm	110mm	130mm	310mm	
Light curtain height	106mm	126mm	146mm	166mm	186mm	366mm	
Model NO.	NPN NC	BML10-T0603NC	BML10-T0803NC	BML10-T1003NC	BML10-T1203NC	BML10-T1403NC	BML10-T3203NC
	PNP NC	BML10-T0603PC	BML10-T0803PC	BML10-T1003PC	BML10-T1203PC	BML10-T1403PC	BML10-T3203PC

Remarks: maximum number of optical axes 70 axes.

BML14

Beam pitch	14mm							
Min. sized detectable objects	> ϕ 19mm, opaque							
Protection distance	0.3~3m							
NO.of beams	6	8	10	12	14	32	
Protection height	70mm	98mm	126mm	154mm	182mm	434mm	
Light curtain height	128mm	156mm	184mm	212mm	240mm	492mm	
Model NO.	NPN NC	BML14-T0603NC	BML14-T0803NC	BML14-T1003NC	BML14-T1203NC	BML14-T1403NC	BML14-T3203NC
	PNP NC	BML14-T0603PC	BML14-T0803PC	BML14-T1003PC	BML14-T1203PC	BML14-T1403PC	BML14-T3203PC

BML20

Beam pitch	20mm							
Min. sized detectable objects	> ϕ 25, opaque							
Protection distance	0.3~3m							
NO.of beams	4	6	8	10	12	32	
Protection height	60mm	100mm	140mm	180mm	220mm	620mm	
Light curtain height	115mm	155mm	195mm	235mm	275mm	675mm	
Model NO.	NPN NC	BML20-T0403NC	BML20-T0603NC	BML20-T0803NC	BML20-T1003NC	BML20-T1203NC	BML20-T3203NC
	PNP NC	BML20-T0403PC	BML20-T0603PC	BML20-T0803PC	BML20-T1003PC	BML20-T1203PC	BML20-T3203PC

Remarks: maximum number of optical axes 72 axes.

BML25

Beam pitch	25mm							
Min. sized detectable objects	> ϕ 30, opaque							
Protection distance	0.3~3m							
NO.of beams	6	8	10	12	14	32	
Protection height	125mm	175mm	225mm	275mm	325mm	775mm	
Light curtain height	182.5mm	232.5mm	282.5mm	332.5mm	382.5mm	832.5mm	
Model NO.	NPN NC	BML25-T0603NC	BML25-T0803NC	BML25-T1003NC	BML25-T1203NC	BML25-T1403NC	BML25-T3203NC
	PNP NC	BML25-T0603PC	BML25-T0803PC	BML25-T1003PC	BML25-T1203PC	BML25-T1403PC	BML25-T3203PC

BML30

Beam pitch	30mm							
Min. sized detectable objects	> ϕ 35, opaque							
Protection distance	0.3~3m							
NO.of beams	4	6	8	10	12	32	
Protection height	90mm	150mm	210mm	270mm	330mm	930mm	
Light curtain height	150mm	210mm	270mm	330mm	390mm	990mm	
Model NO.	NPN NC	BML30-T0403NC	BML30-T0603NC	BML30-T0803NC	BML30-T1003NC	BML30-T1203NC	BML30-T3203NC
	PNP NC	BML30-T0403PC	BML30-T0603PC	BML30-T0803PC	BML30-T1003PC	BML30-T1203PC	BML30-T3203PC

BML40

Beam pitch	40mm							
Min. sized detectable objects	> ϕ 45, opaque							
Protection distance	0.3~3m							
NO.of beams	4	6	8	10	12	32	
Protection height	120mm	200mm	280mm	360mm	440mm	1240mm	
Light curtain height	185mm	265mm	345mm	425mm	505mm	1305mm	
Model NO.	NPN NC	BML40-T0403NC	BML40-T0603NC	BML40-T0803NC	BML40-T1003NC	BML40-T1203NC	BML40-T3203NC
	PNP NC	BML40-T0403PC	BML40-T0603PC	BML40-T0803PC	BML40-T1003PC	BML40-T1203PC	BML40-T3203PC

Remarks: maximum number of optical axes 72 axes.

- Fiber Optic
- Slot Sensors
- Photoelectric
- Laser
- Proximity
- Displacement
- Magnetic
- Contact

Guidance

- Light curtains
- Standard type
- Top-emitting type
- Side-emitting type
- Waterproof type
- Measuring type
- Economical type
- Safety Light Curtain
- Beam pitch 10mm
- Beam pitch 20mm
- Beam pitch 30mm
- Beam pitch 40mm
- LIDAR scanner
- TOF LIDAR scanner
- MINI LIDAR scanner
- Navigation LIDAR

Standard Type

BML Series

Area

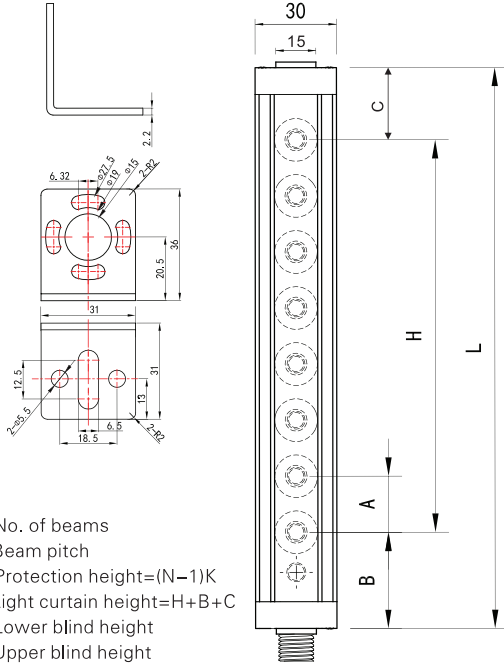

N: No. of beams
 K: Beam pitch
 H: Protection height = (N-1)K
 L: Light curtain height = H+B+C
 B: Lower blind height
 C: Upper blind height

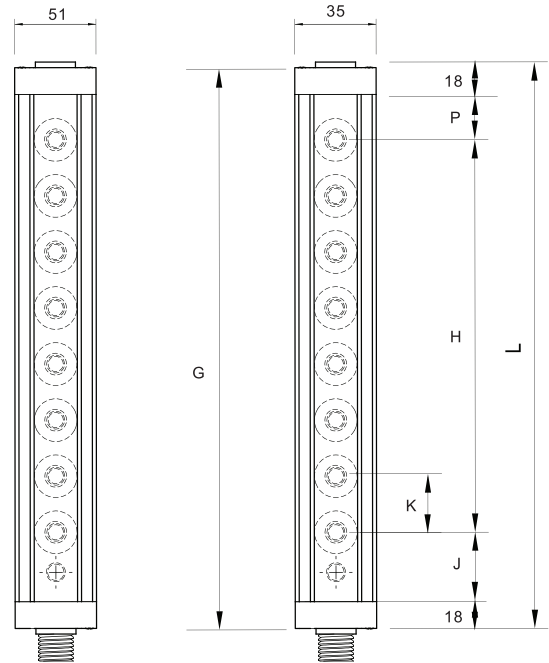

When the detection distance is more than 10m and the number of optical axes exceeds 32 axes:

H: Detection height
 $H = (N-1) * k$
 L: Light curtain height
 N: No. of beams
 $L = P + H + J + 18 + 18$

BML10

K: 10
 H: (N-1)*10
 L: H+56
 B: 41
 C: 15

BML20

K: 20
 H: (N-1)*20
 L: H+55
 B: 35
 C: 20

BML30

K: 30
 H: (N-1)*30
 L: H+60
 B: 35
 C: 25

BML14

K: 14
 H: (N-1)*14
 L: H+58
 B: 41
 C: 17

BML25

K: 25
 H: (N-1)*25
 L: H+57.5
 B: 35
 C: 22.5

BML40

K: 40
 H: (N-1)*40
 L: H+65
 B: 35
 C: 30

K	14	20	25	30	40
P	7	10	12,5	15	20
J	32	25	25	25	25

Connection Diagram

NPN

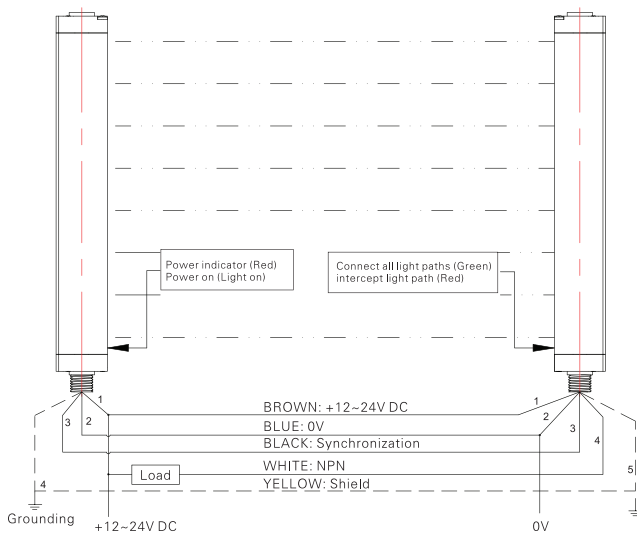

PNP

