



Appearance

Sensing type	Diffuse reflection					
Sensing distance	15~20mm	30~45mm	55~85mm	90~190mm	125~625mm	245~1245mm
F.S	5mm	15mm	30mm	100mm	500mm	1000mm
Light source	Medium. Wave length Max. output power Red semiconductor laser wavelength: 660nm, blue semiconductor laser wavelength: 405nm ≤0.95mw (Low power) , ≤5mw, ≤20mw (High power)					
IEC/JIS	class2 (Low power) , class3R, class3B (High power)					
Linearity	±0.05%					±0.1%
Repeat accuracy	0.01%					0.02%
Sampling period	9400Hz					
Temperature drift	0.02% F.S./°C					
Output	Analog current	Output 4 ~ 20mA, allowable load resistance 500 Ω				
	Analog voltage	0~10v output, output resistance 100 Ω				
Digital output	RS232orRS485					
Operating voltage	9~36V					
Power consumption	1.5~2W					
Synchronous input	2.4~24V					
Logic output	Programming function,NPN:100mA Max,40V Max					
Ambient parameters	Degree of protection	IP67				
	Ambient temperature	-10°C~+60°C, No freezing				
	Ambient humidity	5%~95% RH, No condensation				
	Ambient illuminance	10000Lux (Low power) , 30000lux, >30000lux (High power)				
	Vibration resistance	20g/10~1000Hz, 6 hours in each direction of XYZ				
Shock resistance	30g/6ms					
Material	Housing: aluminum					
Weight	≈ 100g					
485 Voltage output	MLD27-5V-485	MLD27-15V-485	MLD27-30V-485	MLD27-100V-485	MLD27-500V-485	MLD27-1000V-485
232 Voltage output	MLD27-5V-232	MLD27-15V-232	MLD27-30V-232	MLD27-100V-232	MLD27-500V-232	MLD27-1000V-232
485 Current output	MLD27-5I-485	MLD27-15I-485	MLD27-30I-485	MLD27-100I-485	MLD27-500I-485	MLD27-1000I-485
232 Current output	MLD27-5I-232	MLD27-15I-232	MLD27-30I-232	MLD27-100I-232	MLD27-500I-232	MLD27-1000I-232

- Fiber Optic
- Slot Sensors
- Photoelectric
- Laser
- Proximity
- Displacement**
- Magnetic
- Contact
- Area
- Ultrasonic
- Vibration
- Temperature
- Cables
- Tester

Guidance

Displacement

- TOF measurement
- Mini digital display
- Built-in controller**
- Linear measurement
- Magnetic displacement
- LIDAR Scanner
- Color confocal

Dimensions

Unit: mm

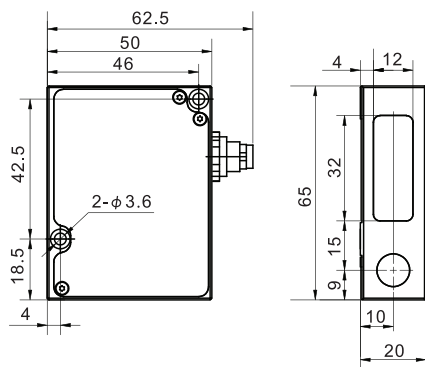

Circuit diagram

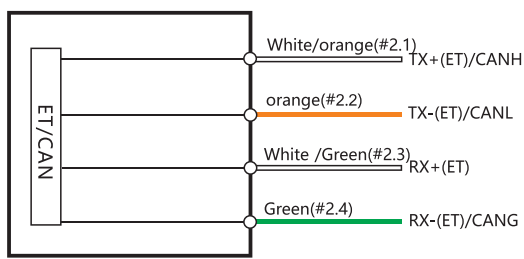
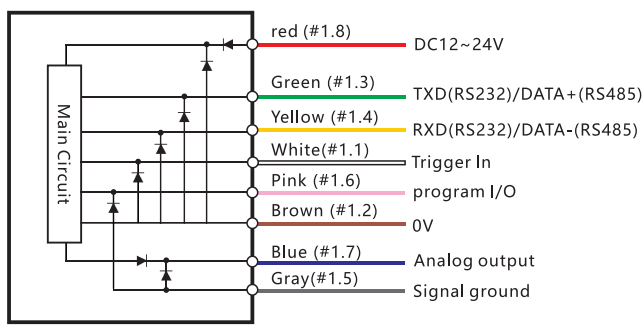

connector #1



connector #2(optional)



Built-in Controller

MLD27-H Series



Appearance

Sensing type	Diffuse reflection					
Sensing distance	15~20mm	30~45mm	55~85mm	65~115mm	90~190mm	80~330mm
F.S	5mm	15mm	30mm	50mm	100mm	250mm
Light source	Red semiconductor laser wavelength (default) : 660nm, blue semiconductor laser wavelength: 405nm					
Medium. Wave length Max. output power	≤4.8mW			≤20mW		
IEC/JIS	3R			3B		
Linearity	± 0.1 (60 kHz); ± 0.2 (120 kHz); ± 0.3 (180 kHz)					
Repeat accuracy	0.01 (60 kHz); 0.02 (120 kHz); 0.03 (180 kHz)					
Sampling period	60 or 120 or 180 kHz (default 60K)					
Temperature drift	0.02% F.S./°C					
Output	Output 0 ~ 10V, output impedance 100 Ω					
Digital output	Parameters: RS232 or 485, data transmission: Ethernet (UDP)					
Operating voltage	9~36V					
Power consumption	4.8W					
Synchronous input	2.4~5V(CMOS, TTL)					
Logic output	Programming function,NPN:100mA Max,40V Max					
Degree of protection	IP67					
Ambient temperature	-10°C~+60°C, No freezing					
Ambient humidity	5%~95%RH, No condensation					
Ambient illuminance	30000Lux					
Vibration resistance	20g/10~1000Hz, 6 hours in each direction of XYZ					
Shock resistance	30g/6ms					
Material	Housing: aluminum					
Weight	110g					
485 output	MLD27-H5V-485	MLD27-H15V-485	MLD27-H30V-485	MLD27-H50V-485	MLD27-H100V-485	MLD27-H250V-485
232 output	MLD27-H5V-232	MLD27-H15V-232	MLD27-H30V-232	MLD27-H50V-232	MLD27-H100V-232	MLD27-H250V-232

Dimensions

Unit: mm

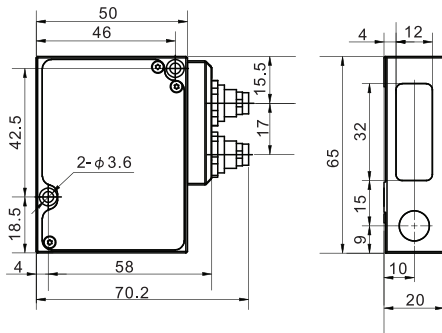

Circuit diagram

