

Square

PTJ-I Series



Appearance			
Sensing type	Thru-beam		
Sensing distance	80cm (fixed)	150cm (fixed)	
Standard test object	Opaque objects above ϕ 6mm		
Output type	NPN/PNP Open-collector		
Switch type	Selectable L.on/D.on, Model optional		
Response frequency	150Hz		
Indicator	Transmitter: Power indicator: green; Receiver: Action indicator: yellow		
Light source	Infrared LED 850nm (Modulated)		
Operating voltage	12~24V DC		
Residual voltage	2V or less (when the current is 50mA)		
Current consumption	The transmitting end < 15mA, Receiving end < 15mA		
Load current	< 50mA		
Protective circuit	Reverse polarity , short circuit		
Ambient brightness	Sunlight \leq 10000Lux, Incandescent lamp \leq 3000Lux		
Ambient temperature	-20°C~+50°C, No freezing		
Voltage drop	35~90% RH, Storage : 35~90% RH		
Storage temperature	-30°C~+70°C, No freezing		
Voltage withstandability	\geq 20M Ω /500V DC		
Pressure strength	AC1000V(50/60Hz)1minute		
Shock resistance	10~55Hz reciprocating amplitude 1.5mm, X, Y, Z directions 2 hours		
Impact resistant	500m/s ² XYZ three directions		
Degree of protection	IP 64		
Housing Material	PC/ABS		
Connection method	2M 3core cable		
Model No.	NPN D.on	PTJ-T80NO-I	PTJ-T150NO-I
	NPN L.on	PTJ-T80NC-I	PTJ-T150NC-I
	PNP D.on	PTJ-T80PO-I	PTJ-T150PO-I
	PNP L.on	PTJ-T80PC-I	PTJ-T150PC-I

Dimensions

Unit: mm

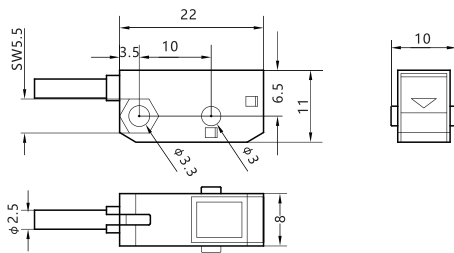

Circuit diagram

NPN Output

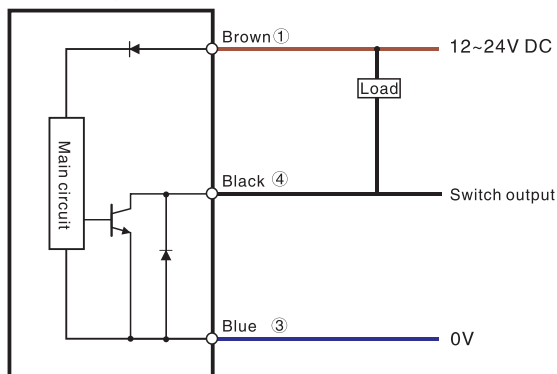

PNP Output

